

DNA/DNR-DIO-433-800

Guardian™ 32-Channel Industrial Digital Output Board

The Guardian Advantage

- Programmable overcurrent protection (50 mA to 1 A)
- Programmable overcurrent duration limits
- PWM based soft-start/stop reduces inrush current “shock”
- Monitors each channel’s output current allowing automatic detection of shorts/open and other system failures
- Low leakage outputs mean LED indicators look off, even when viewed through night-vision goggles
- PWM output for control of low speed, high current analog devices
- 600 mA per channel of continuous output (source) current
- Wide 3.3 V to 36 V operating range

10-Year
Availability
Guarantee



[DNR-DIO-433-800 Shown]

DNA-DIO-433-800 boards are for use in “Cube” chassis while the DNR-DIO-433-800 is designed for use in RACKtangle™ chassis

General Description:

The DNA/DNR-DIO-433-800 are 32 channel, digital output boards designed for use in a wide variety of applications. The DNA-DIO-433-800 and DNR-DIO-433-800 are compatible with UEI’s popular “Cube” and RACKtangle I/O chassis respectively. Each output channel is configured as a current source (see diagram on the next page) and switches voltages between 3.3 and 36 VDC. Each channel is rated for continuous operation at 600 mA with an output voltage drop of less than 550 mV. Based on the popular DNx-DIO-433, the 433-800 provides lower leakage outputs. This is critical in simulator applications where LED indicators will be view through night vision devices as the 25 uA leakage in teh standard version is enough to make an LED look on.

As part of UEI’s Guardian series the board not only controls the digital outputs, it provides a unique monitoring capability. An on-board 24-bit A/D converter monitors each channel’s output current. This allows the application to detect short and open circuits as well as other “suspicious” behavior. The monitoring capability is also powerful diagnostic tool allowing a repair technician to quickly and accurately identify blown, or mis-wired channels. With the output “On”, each channel will input current (0-600mA).

The Guardian advantage includes programmable overcurrent protection. The user may select the current and duration of overload (as short as 10 ms) required before the channel is shut down. Each board provides 350 Vrms isolation between the I/O and the cube and other installed I/O layers. The DNA-DIO-433-800 offers update rates up to 1 kHz and simplifies software writes by transferring all data in a single, 32-bit word.

Each channel offers a pulse-width-modulated (PWM) “soft-start/stop” capability, allowing power to be applied/removed gradually, greatly increasing the reliability of devices like incandescent bulbs where thermal shock reduces life expectancy. The PWM output may also be used to drive low speed, high current analog devices or may be used as a “dimmer”.

The DNA-DIO-433-800 is fully supported by the UEIDAQ Framework which provides a simple and complete software interface to all popular programming languages, operating systems and data acquisition and control applications (e.g. LabVIEW, DASyLab, MATLAB).

Technical Specifications:

Number of channels	32 digital outputs
Output configuration	Current source
Output port configuration	Single 32-bit word
Output Drive	600 mA per channel continuous; 3.5 A peak 10% Duty Cycle 100 ms max)
Output ON voltage drop	< 500 mV @ 600 mA (Incl. std 3’ cable)
Output ON impedance	< 0.9 Ohm (Includes standard 3’ cable)
Output OFF impedance	> 1 Meg Ohm
Output OFF leakage	< 1 µA
Overvoltage protection	±40 VDC (reverse current must be limited to 1 A to prevent damage)
Overcurrent protection	
Current Limit	50 mA - 2 A (user-programmable)
Overload response time	10-5000 ms (user programmable)
Output Monitoring	
Configuration	Multiplexed, one A/D
Current Accuracy	±1 mA, max (sampled at 10 Hz)
Soft-Start/Stop Duration	256 µS to 5 seconds
Steady State PWM Output	0 to 100% in 0.4% increments (Minimum period is 256 µS)
Output Throughput Rate	1 kHz max
Power up / reboot state	Off
Isolation	350 Vrms
Power dissipation	< 2 W, not including output switches
Operating Temp. Range	Tested -40 to +85 °C
Operating Humidity	95%, non-condensing
Vibration IEC 60068-2-6	5 g, 10-500 Hz, sinusoidal
IEC 60068-2-64	5 g (rms), 10-500 Hz, broad-band random
Shock IEC 60068-2-27	50 g, 3 ms half sine, 18 shocks @ 6 orientations 30 g, 11 ms half sine, 18 shocks @ 6 orientations
MTBF	260,000 hours

Block Diagram:

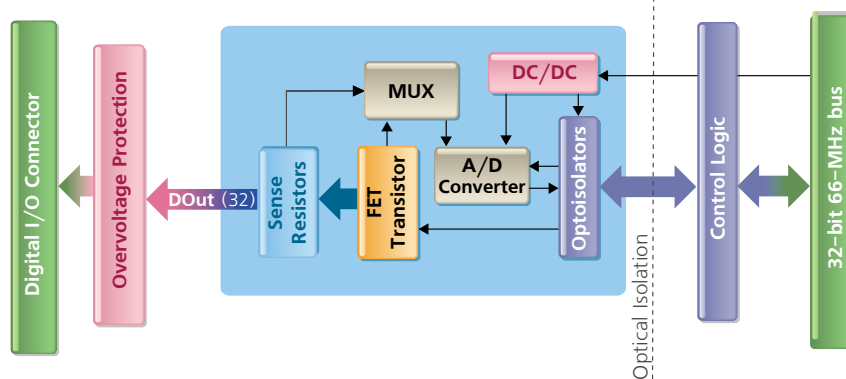

Connection Options:

Screw Terminal Panel	Matching Cable	Description
DNA-STP-62	DNA-CBL-62	Connects all I/O signals to easy to use screw terminals

Single Channel Diagram:

Simplified Output Channel Diagram

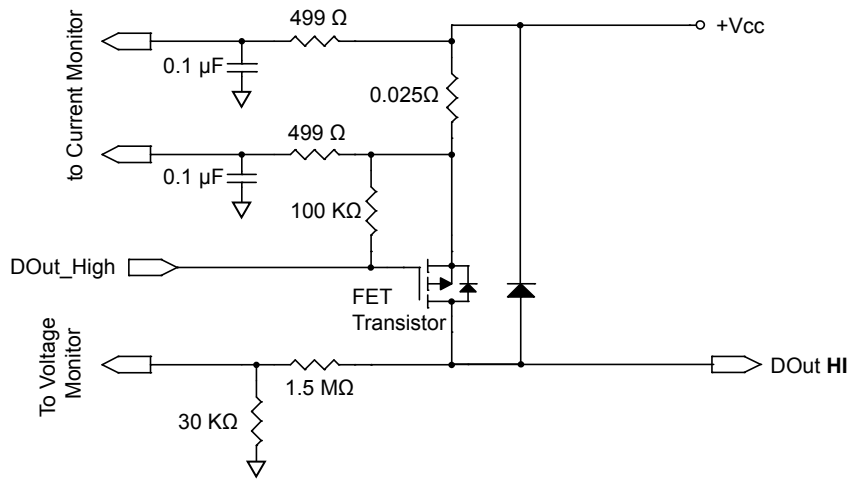

Pinout Diagram:

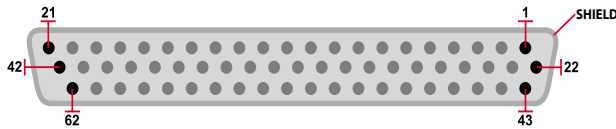

Pin	Signal	Pin	Signal	Pin	Signal
1	+Vcc	22	+Vcc	43	+Vcc
2	+Vcc	23	+Vcc	44	+Vcc
3	DO 1	24	DO 0	45	DO 2
4	DO 4	25	DO 3	46	DO 5
5	+Vcc	26	+Vcc	47	+Vcc
6	DO 7	27	DO 6	48	DO 8
7	DO 10	28	DO 9	49	DO 11
8	+Vcc	29	+Vcc	50	+Vcc
9	DO 13	30	DO 12	51	DO 14
10	DO 16	31	DO 15	52	DO 17
11	+Vcc	32	+Vcc	53	+Vcc
12	DO 19	33	DO 18	54	DO 20
13	DO 22	34	DO 21	55	DO 23
14	+Vcc	35	+Vcc	56	+Vcc
15	DO 25	36	DO 24	57	Rsvd
16	DO 27	37	DO 26	58	Rsvd
17	+Vcc	38	+Vcc	59	Rsvd
18	DO 29	39	DO 28	60	Rsvd
19	DO 31	40	DO 30	61	Rsvd
20	+Vcc	41	+Vcc	62	+Vcc
21	+Vcc	42	+Vcc		

Note: For rated performance all +Vcc pins should be connected to +Vcc.